

**WELDING MANIPULATOR MODEL WM 40400**  
**WITH VARIABLE SPEED ON TROLLEY**  
**CONFIGURATION FOR STEEL BOXES WELDING**

**FEATURES:**

1. Boom vertical effective expansion: 4.0 m
2. Boom horizontal effective expansion: 4.0 m
3. Boom expansion speed (in-out): From 0.12 up to 1.2 m/min
4. Boom lifting speed (up-down): 1.0 m/min
5. Boom extremity max load: 200 kilograms @ 12" GC
6. Trolley motorized (approx.): 0.15 to 1.5 m/minute
7. Column rotation motorized (approx.): 0.03 to 0.30 RPM
8. Column rotation motorized:  $\pm 180^\circ$
9. Column height (approx.): 6.49 m
10. WM 4040 include two Idler bogies with stoppers for adjust position (red ellipse). Each bogie include a manual cross slide for fine vertical and horizontal adjustment. Stroke: 80 mm x 80 mm. Max load capacity: 50 kg @ 12' GC. Picture see below.
11. Lincoln Eqp: Not included unless otherwise has been specified.

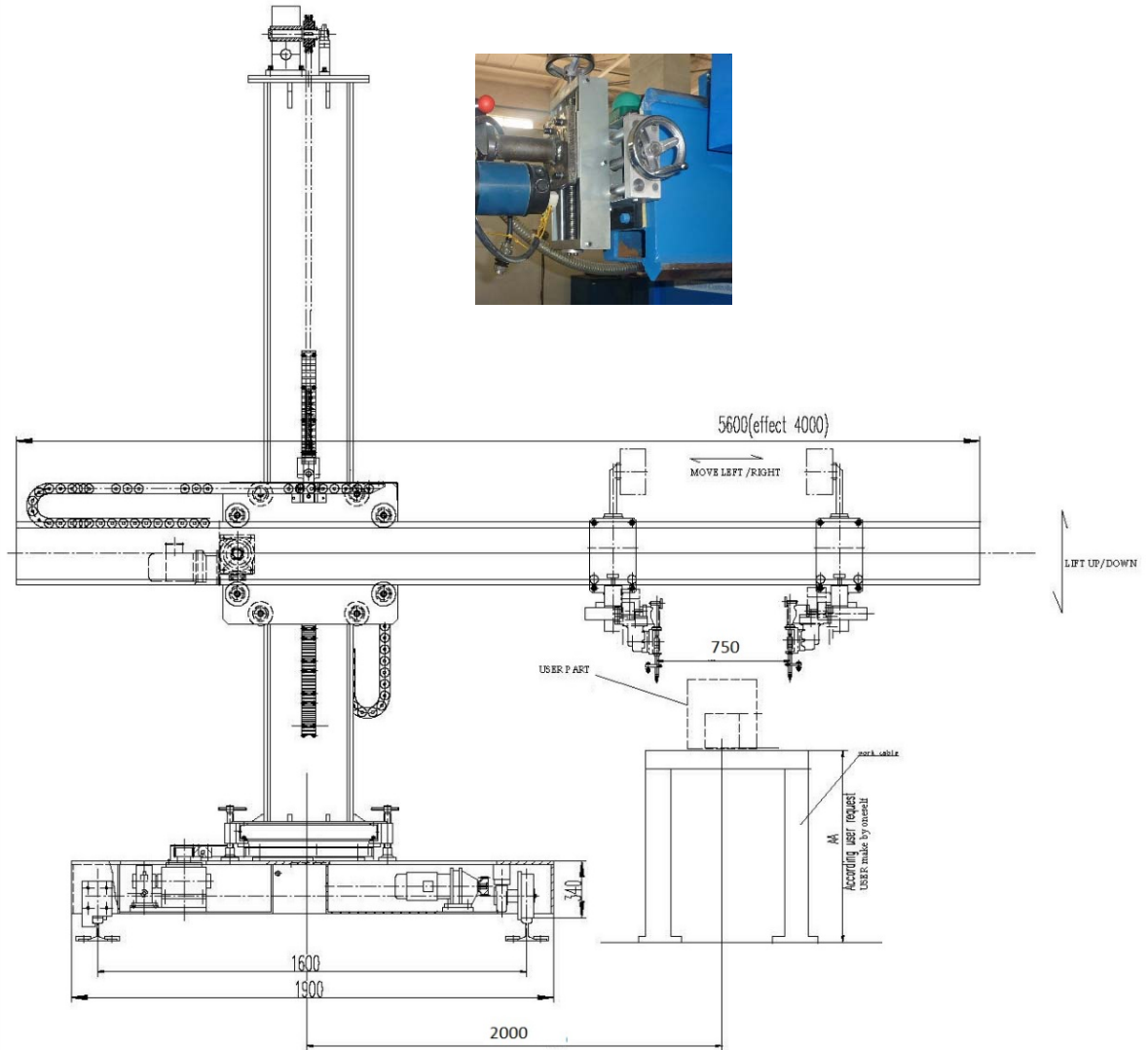

**IRIZAR HEAVY INDUSTRIES INC**  
 1512 ADAMSON VIEW, EDMONTON  
 ALBERTA T6W 0V4, CANADA  
 PHONE: 1 780 450 6695  
 WEB: WWW.IRIZAR.COM

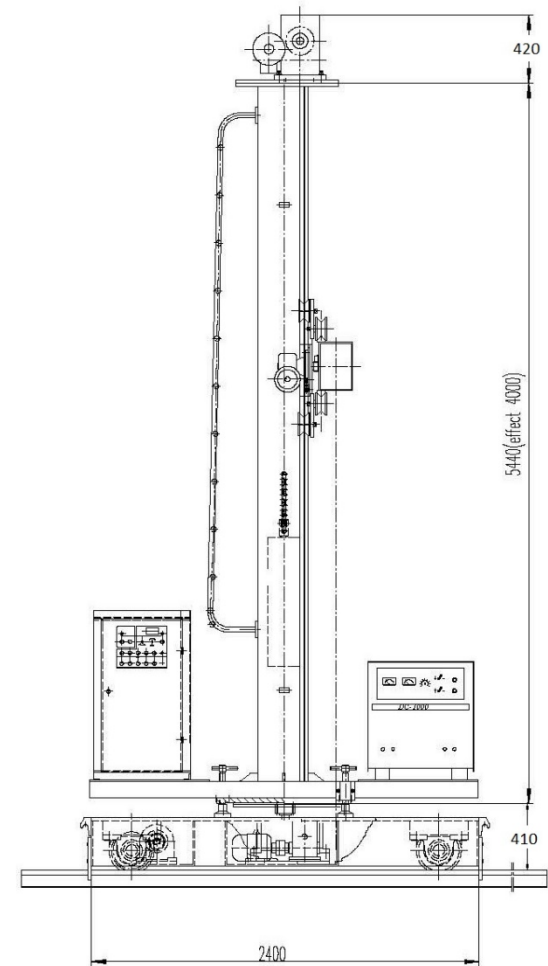
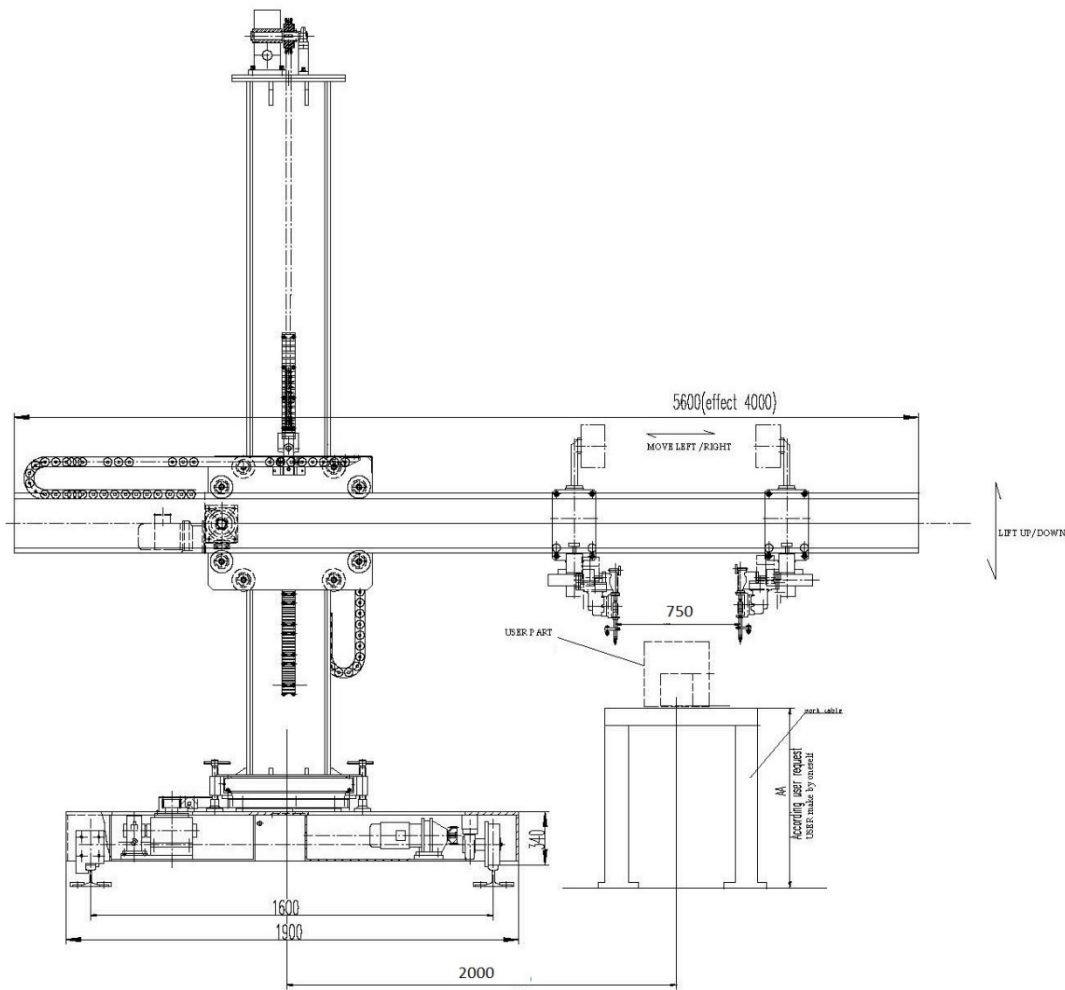

**IRIZAR**

IRIZAR HEAVY INDUSTRIES INC  
 1512 ADAMSON VIEW, EDMONTON  
 ALBERTA T6W 0V4, CANADA  
 PHONE: 1 780 450 6695  
 WEB: WWW.IRIZAR.COM